

UNIT REFERENCE:
 TRAILER 130L
 TRAILER 133L
 TRAILER 139L

70,000 PPH 395 PSI RENTAL BOILER

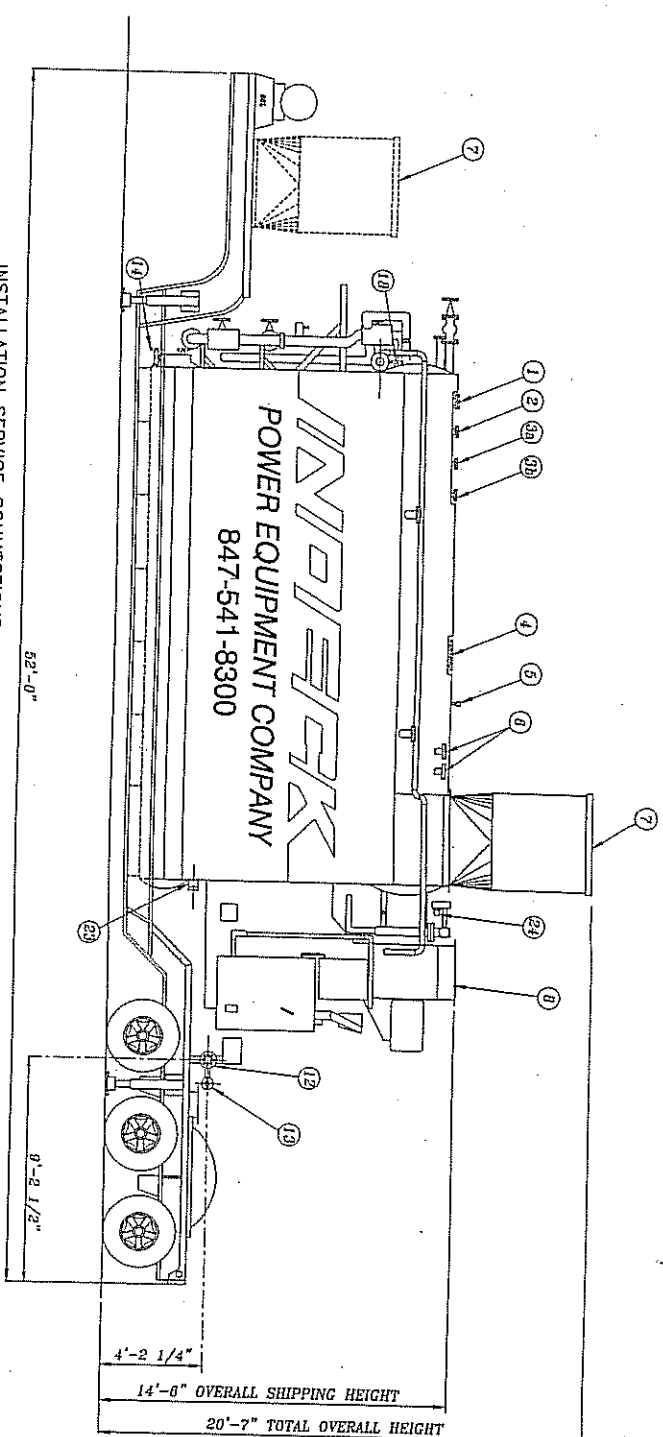

INSTALLATION SERVICE CONNECTIONS

1. 4"-600# SAFETY VALVE CONNECTION (SAFETY VALVE MUST BE REMOVED FOR TRANSPORT)
2. 4"-600# SAFETY VALVE CONNECTION (SAFETY VALVE MUST BE REMOVED FOR TRANSPORT)
- 3a. 2"-600# SAFETY VALVE CONNECTION (SAFETY VALVE MUST BE REMOVED FOR TRANSPORT)
- 3b. 2"-600# SAFETY VALVE CONNECTION (SAFETY VALVE MUST BE REMOVED FOR TRANSPORT)
4. 1" NPT GRIM VENT / AUX CONNECTION
5. 2"-1/2" NPT GRIM VENT / AUX CONNECTION
7. FUEL GAS STACK AND TRANSPORT (REMOVABLE TO PROVIDE ADDITIONAL SHIPPING CLEARANCE (FLANGED))
9. 1/2" NPT GRIM VENT / AUX CONNECTION (LOCATED BEHIND CABINET)
10. 1/2" NPT PILOT GAS CONNECTIONS (NAT OR PROPANE)
11. 3/4" NPT FUEL OIL INLET (LOCATED ON OPPOSITE SIDE OF TRAILER)
12. 4"-150 # FUEL GAS CONNECTION
13. 2"-150 # GAS VENT OUTLET
14. 1"-1/2" NPT GRIM VENT / AUX CONNECTION
15. 3/4" NPT GRIM VENT / AUX CONNECTION
17. 1" CONTINUOUS FUEL FEED CONNECTION (LOCATED ON OPPOSITE SIDE OF TRAILER)
18. 2"-1/2" NPT GRIM VENT / AUX CONNECTION
19. 450/60/3 POWER SUPPLY 150 AMPS
20. 2"-300# SOOT BLOWER STEAM SUPPLY CONNECTION
21. 2"-300# CHEMICAL CLEANING CONNECTION
22. WASH TANK PERFORMANCE PRESS CONNECTION
24. 1" NPT INSTRUMENT AIR CONNECTION

DESIGN DATA

OVERALL LENGTH: 52'-0"
 OVERALL WIDTH: 10'-6"
 NET WEIGHT (VAC. TRAILER): 99,790 LBS
 GROSS WEIGHT: 107,000 PPH
 DESIGN PRESSURE: 395 PSIG F
 FURNACE VOLUME: 854 CU. FT.
 CONNECTION HEATING SURFACE: 3480 SQ. FT.
 RADIANT HEATING SURFACE: 4110 SQ. FT. (A.S.M.E.)
 NOTE: HEATING SURFACE (REGULATED BY CUSTOMER)
 OIL SUPPLY PRESSURE: 10 PSIG (FLOODED MAX.)
 FUEL WATER PRESSURE: 20-100 PSIG ABOVE OPERATING PRESSURE
 INSTRUMENT AIR PRESSURE: 50-100 PSI
 NOTE: A NATURAL GAS OR PROPANE PILOT IS REQUIRED ON ALL UNITS.
 NOTE 2: PROVIDE ADEQUATE WEATHER PROTECTION FOR BURNER, CONTROLS AND PERSONNEL.

INDECK 70,000 PPH RENTAL BOILER

INDECK POWER EQUIPMENT COMPANY 1111 WILLIS AVENUE WHEELING, ILLINOIS 60090